



Model:SC25G610D2

◎ POWER RATING

Engine Speed	Type of	Gross Engine Output	Net Engine Output
rpm	Operation	kW	kW
1500	Prime Power	405	383
	Standby Power	445	423

-. The engine performance is as per GB/T2820.

-. Ratings are based on GB/T1147.1.

---Prime power is available for an unlimited number of hours per year in a variable load application. The permissible average power output over 24 hours of operation shall not exceed 80% of the prime power rating.

---Standby power is available in the event of a utility power outage or under test conditions for up to 200 hours of operation per year. The permissible average power output over 24 hours of operation shall not exceed 80% of the standby power rating.

◎ SPECIFICATIONS

○ Engine Model	SC25G610D2
○ Engine Type	V-type,4 strokes, water-cooled Turbo charged air-to-air intercooled
○ Combustion type	Direct injection
○ Cylinder Type	Wet liner
○ Number of cylinders	12
○ Bore × stroke	135(5.32) × 150(5.9) mm(in.)
○ Displacement	25.8(1574) lit.(in3)
○ Compression ratio	16 : 1
○ Firing order	1-12-5-8-3-10-6-7-2-11-4-9
○ Injection timing	14.5°BTDC
○ Dry weight	Approx. 2080kg (4585 lb)
○ Dimension (L×W×H)	1930×1686×1872mm (76×66.4×75.8 in.)
○ Rotation	Counter clockwise viewed from

◎ FUEL CONSUMPTION

○ Power	lit/hr
25%	30.9
50%	53.6
75%	75.8
100%	100.4
110%	112.7

◎ FUEL SYSTEM

○ Injection pump	Yijie in-line “P” type
○ Governor	Electric type
○ Feed pump	Mechanical type
○ Injection nozzle	Multi hole type
○ Opening pressure	240kg/cm2 (3414 psi)



	Flywheel		○ Fuel filter	Full flow, cartridge type
○ Fly wheel housing	SAE NO. 1/2		○ Used fuel	Diesel fuel oil
○ Fly wheel	SAE NO.14			
◎ MECHANISM		◎ LUBRICATION SYSTEM		
○ Type	Over head valve		○ Lub. Method	Fully forced pressure feed type
○ Number of valve	Intake 1, exhaust 1 per cylinder		○ Oil pump	Gear type driven by crankshaft
○ Valve lashes at cold	Intake 0.325mm (0.0128 in.)		○ Oil filter	Full flow, cartridge type
	Exhaust 0.375mm (0.0148 in.)		○ Oil pan capacity	High level 65 liters (17.16 gal.) Low level 55 liters (14.52 gal.)
◎ VALVE TIMING			○ Angularity limit	Front down 25 deg. Front up 35 deg. Side to side 35 deg.
	Opening	Close		
○ Intake valve	20 deg. BTDC	48 deg. ABDC		
○ Exhaust valve	48 deg. BBDC	20 deg. ATDC	○ Lub. Oil	Refer to Operation Manual
◎ COOLING SYSTEM		◎ ENGINEERING DATA		
○ Cooling method	Fresh water forced circulation		○ Water flow	740 liters/min @1,500 rpm
○ Water capacity (engine only)	48 liters (12.7 gal.)		○ Heat rejection to coolant	40.7 kcal/sec @1,500 rpm
			○ Heat rejection to CAC	25.5 kcal/sec @1,500 rpm
○ Pressure system	Max. 0.5 kg/cm2 (7.11 psi)		○ Engine waste heat	12.7 kcal/sec @1,500 rpm
○ Water pump	Centrifugal type driven by belt		○ Air flow	32 m3/min @1,500 rpm
○ Water pump Capacity	740 liters (195.36 gal.)/min		○ Exhaust gas flow	86 m3/min @1,500 rpm
	at 1,500 rpm (engine)		○ Exhaust gas temp.	650 °C @1,500 rpm
○ Thermostat	Wax–pellet type		○ Max. permissible restrictions	
	Opening temp. 77°C Full open temp. 90°C		Intake system	3 kPa initial



- Cooling fan
 - Blower type, iron
 - 1100 mm diameter, 6 blades
- Cooling air flow
 - 12.76 m³ /s

- Exhaust system
 - 6 kPa final
 - 6 kPa max.
- Max. permissible altitude
 - 2,000 m

- Fan power
 - 20 kW

◎ **ELECTRICAL SYSTEM**

- Charging generator
 - 28V×55A
- Voltage regulator
 - Built-in type IC regulator
- Starting motor
 - 24V×11kW
- Battery Voltage
 - 24V
- Battery Capacity
 - 200 AH

◆ **CONVERSION TABLE**

- in. = mm × 0.0394
- lb/ft = N.m × 0.737
- PS = kW × 1.3596
- U.S. gal = lit. × 0.264
- psi = kg/cm² × 14.2233
- kW = 0.2388 kcal/s
- in³ = lit. × 61.02
- lb/PS.h = g/kW.h × 0.00162
- hp = PS × 0.98635
- cfm = m³/min × 35.336
- lb = kg × 2.20462

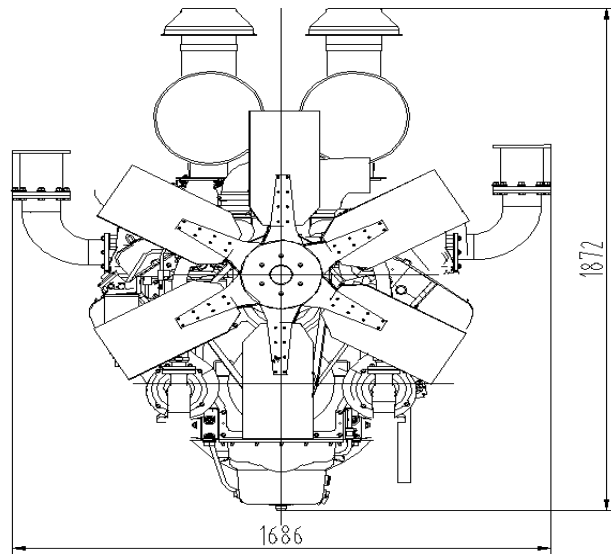
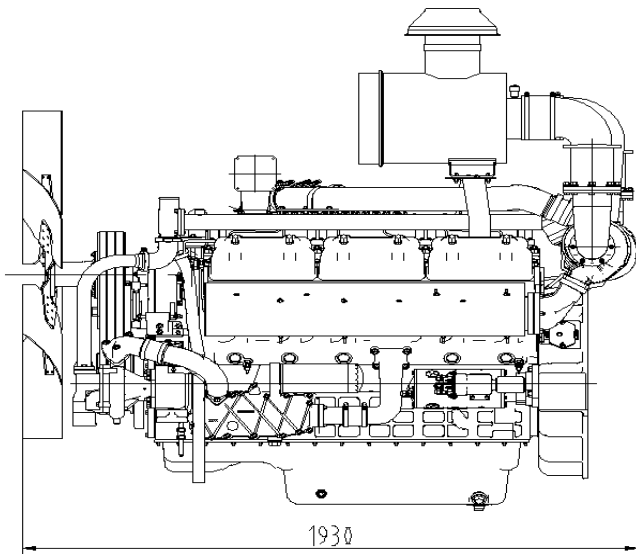

	Initial load acceptance when engine reaches rated speed (15 seconds maximum after engine starts to crank)				2nd load application Immediately after engine has recovered to rated speed (5 seconds after initial load application)			
	Engine speed	Prime power %	Load kWm (kWe) Nett	Transient Frequency deviation %	Frequency recovery time seconds	Prime power %	Load kWm (kWe) Nett	Transient Frequency deviation %
1500 rev/min	65	263	≤7	3	45	182	≤7	3