



## Model:SC33W990D2

### ◎ POWER RATING

Engine Speed	Type of	Gross Engine Output	Net Engine Output
rpm	Operation	kW	kW
1500	Prime Power	660	632
	Standby Power	726	698

-. The engine performance is as per GB/T2820.

-. Ratings are based on GB/T1147.1.

---Prime power is available for an unlimited number of hours per year in a variable load application. The permissible average power output over 24 hours of operation shall not exceed 80% of the prime power rating.

---Standby power is available in the event of a utility power outage or under test conditions for up to 200 hours of operation per year. The permissible average power output over 24 hours of operation shall not exceed 80% of the standby power rating.

### ◎ SPECIFICATIONS

○ Engine Model	SC33W990D2
○ Engine Type	line, 4 strokes, water-cooled Turbo charged air-to-air intercooled
○ Combustion type	Direct injection
○ Cylinder Type	Wet liner
○ Number of cylinders	6
○ Bore × stroke	180(7.09) × 215(8.47) mm(in.)
○ Displacement	32.8(2001) lit.(in3)
○ Compression ratio	15 : 1
○ Firing order	1-5-3-6-2-4
○ Injection timing	22°BTDC
○ Dry weight	Approx. 3400kg (7495.7 lb)
○ Dimension (L×W×H)	2307×1371×1983 mm (90.9×54.0×78.1 in.)
○ Rotation	Counter clockwise viewed from

### ◎ FUEL CONSUMPTION

○ Power	lit/hr
25%	44.8
50%	84.3
75%	123.9
100%	163.7
110%	182.3
<b>◎ FUEL SYSTEM</b>	
○ Injection pump	Longkou in-line “P11” type
○ Governor	Electric type
○ Feed pump	Mechanical type
○ Injection nozzle	Multi hole type
○ Opening pressure	290kg/cm2 (4125 psi)



	Flywheel		○ Fuel filter	Full flow, cartridge type
○ Fly wheel housing	SAE NO.0		○ Used fuel	Diesel fuel oil
○ Fly wheel	SAE NO.18			
<b>◎ MECHANISM</b>			<b>◎ LUBRICATION SYSTEM</b>	
○ Type	Over head valve		○ Lub. Method	Fully forced pressure feed type
○ Number of valve	Intake 1, exhaust 1 per cylinder		○ Oil pump	Gear type driven by crankshaft
○ Valve lashes at cold	Intake 0.4mm (0.0158 in.)		○ Oil filter	Full flow, cartridge type
	Exhaust 0.45mm (0.0177 in.)		○ Oil pan capacity	High level 75 L ( 19.8 gal.) Low level 50 L ( 13.2 gal.)
<b>◎ VALVE TIMING</b>			○ Angularity limit	Front down 25 deg. Front up 35 deg. Side to side 35 deg.
	<b>Opening</b>	<b>Close</b>		
○ Intake valve	58° BTDC	48° ABDC	○ Lub. Oil	Refer to Operation Manual
○ Exhaust valve	54° BBDC	48° ATDC		
<b>◎ COOLING SYSTEM</b>			<b>◎ ENGINEERING DATA</b>	
○ Cooling method	Fresh water forced circulation		○ Water flow	1150L/min @1,500 rpm
○ Water capacity (engine only)	56L ( 14.78 gal.)		○ Heat rejection to coolant	66.4kcal/sec @1,500 rpm
			○ Heat rejection to CAC	41.5kcal/sec @1,500 rpm
○ Pressure system	Max. 0.5 kg/cm2 ( 7.11 psi)		○ Engine waste heat	20.7 kcal/sec @1,500 rpm
○ Water pump	Centrifugal type driven by belt		○ Air flow	62.9m3/min @1,500 rpm
○ Water pump Capacity	1150L(303.6gal.)/min		○ Exhaust gas flow	152.6m3/min @1,500 rpm
	at 1,500 rpm (engine)		○ Exhaust gas temp.	680 °C @1,500 rpm
○ Thermostat	Wax–pellet type		○ Max. permissible	
	Opening temp. 77°C		restrictions	
	Full open temp. 90°C		Intake system	3 kPa initial



- Cooling fan
  - Blower type,iron
  - 1371 mm diameter, 8 blades
- Cooling air flow
  - 20.82 m<sup>3</sup> /s

- Exhaust system
  - 6 kPa final
  - 6 kPa max.
- Max. permissible altitude
  - 2,000 m

- Fan power
  - 25 kW

◎ **ELECTRICAL SYSTEM**

- Charging generator
  - 28V×55A
- Voltage regulator
  - Built-in type IC regulator
- Starting motor
  - 24V×11kW
- Battery Voltage
  - 24V
- Battery Capacity
  - 200 AH

◆ **CONVERSION TABLE**

- in. = mm × 0.0394
- PS = kW × 1.3596
- psi = kg/cm<sup>2</sup> × 14.2233
- in<sup>3</sup> = lit. × 61.02
- hp = PS × 0.98635
- lb = kg × 2.20462
- lb/ft = N.m × 0.737
- U.S. gal = lit. × 0.264
- kW = 0.2388 kcal/s
- lb/PS.h = g/kW.h × 0.00162
- cfm = m<sup>3</sup>/min × 35.336

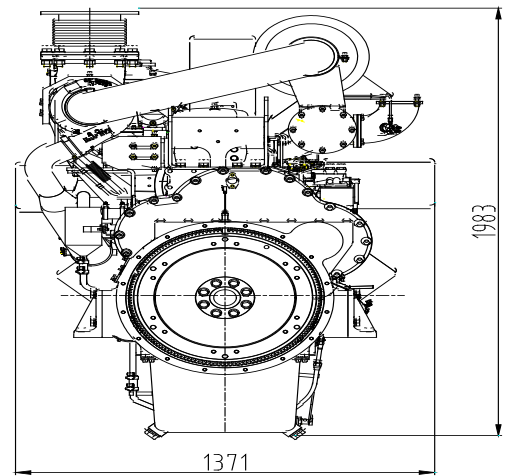
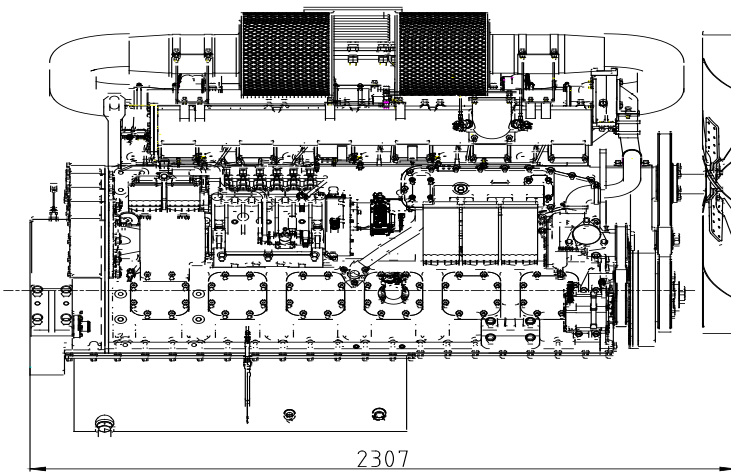

	Initial load acceptance when engine reaches rated speed (15 seconds maximum after engine starts to crank)				2nd load application Immediately after engine has recovered to rated speed (5 seconds after initial load application)			
	Engine speed	Prime power %	Load kWm (kWe) Nett	Transient Frequency deviation %	Frequency recovery time seconds	Prime power %	Load kWm (kWe) Nett	Transient Frequency deviation %
1500 rev/min	50	330	≤7	3	35	231	≤7	3