



Model:SC9D340D2

◎ POWER RATING

Engine Speed	Type of	Gross Engine Output	Net Engine Output
rpm	Operation	kW	kW
1500	Prime Power	228	219
	Standby Power	255	246

-. The engine performance is as per GB/T2820.

-. Ratings are based on GB/T1147.1.

---Prime power is available for an unlimited number of hours per year in a variable load application. The permissible average power output over 24 hours of operation shall not exceed 80% of the prime power rating.

---Standby power is available in the event of a utility power outage or under test conditions for up to 200 hours of operation per year. The permissible average power output over 24 hours of operation shall not exceed 80% of the standby power rating.

◎ SPECIFICATIONS

○ Engine Model	SC9D340D2
○ Engine Type	In-line,4 strokes, water-cooled 4 valves, Turbo charged air-to-air intercooled
○ Combustion type	Direct injection
○ Cylinder Type	Wet liner
○ Number of cylinders	6
○ Bore × stroke	114(4.49) × 144(5.67) mm(in.)
○ Displacement	8.82(538.2) lit.(in ³)
○ Compression ratio	16.5 : 1
○ Firing order	1-5-3-6-2-4
○ Injection timing	8.5°BTDC
○ Dry weight	Approx.840 kg (1852 lb)
○ Dimension (L×W×H)	1578×778×1290 mm (62.2×30.7×50.8 in.)
○ Rotation	Counter clockwise viewed from

◎ FUEL CONSUMPTION

○ Power	lit/hr
25%	14.7
50%	27.3
75%	40.8
100%	54.1
110%	59.6

◎ FUEL SYSTEM

○ Injection pump	Longkou in-line “P” type
○ Governor	Electric type
○ Feed pump	Mechanical type
○ Injection nozzle	Multi hole type
○ Opening pressure	250 kg/cm ² (3556 psi)



	Flywheel		○ Fuel filter	Full flow, cartridge type
○ Fly wheel housing	SAE NO.2		○ Used fuel	Diesel fuel oil
○ Fly wheel	SAE NO.11.5			
◎ MECHANISM			◎ LUBRICATION SYSTEM	
○ Type	Over head valve		○ Lub. Method	Fully forced pressure feed type
○ Number of valve	Intake 2, exhaust 2 per cylinder		○ Oil pump	Gear type driven by crankshaft
○ Valve lashes at cold	Intake 0.30mm (0.0118 in.)		○ Oil filter	Full flow, cartridge type
	Exhaust 0.55mm (0.0217 in.)		○ Oil pan capacity	High level 25 liters (6.6 gal.) Low level 22 liters (5.8 gal.)
◎ VALVE TIMING			○ Angularity limit	Front down 25 deg. Front up 35 deg. Side to side 35 deg.
	Opening	Close		
○ Intake valve	29.5 deg. BTDC	42. 5deg. ABDC		
○ Exhaust valve	69.5 deg. BBDC	34.5 deg. ATDC	○ Lub. Oil	Refer to Operation Manual
◎ COOLING SYSTEM			◎ ENGINEERING DATA	
○ Cooling method	Fresh water forced circulation		○ Water flow	200 liters/min @1,500 rpm
○ Water capacity (engine only)	12 liters (3.17 gal.)		○ Heat rejection to coolant	22.9 kcal/sec @1,500 rpm
			○ Heat rejection to CAC	14.3 kcal/sec @1,500 rpm
○ Pressure system	Max. 0.5 kg/cm2 (7.11 psi)		○ Engine waste heat	7.2 kcal/sec @1,500 rpm
○ Water pump	Centrifugal type driven by belt		○ Air flow	18.6 m3/min @1,500 rpm
○ Water pump Capacity	200 liters (52.8 gal.)/min		○ Exhaust gas flow	41 m3/min @1,500 rpm
	at 1,500 rpm (engine)		○ Exhaust gas temp.	600 °C @1,500 rpm
○ Thermostat	Wax–pellet type		○ Max. permissible	
	Opening temp. 82°C		restrictions	
	Full open temp. 93°C		Intake system	3 kPa initial



○ Cooling fan Blower type, plastic 6 kPa final
 762 mm diameter, 10 blades Exhaust system 6 kPa max.

○ Cooling air flow 6.97 m³/s ○ Max. permissible altitude 2,000 m

○ Fan power 8 kW

◎ **ELECTRICAL SYSTEM**

○ Charging generator 28V×55A

○ Voltage regulator Built-in type IC regulator

○ Starting motor 24V×7.5kW

○ Battery Voltage 24V

○ Battery Capacity 180 AH

◆ **CONVERSION TABLE**

in. = mm × 0.0394 lb/ft = N.m × 0.737

PS = kW × 1.3596 U.S. gal = lit. × 0.264

psi = kg/cm² × 14.2233 kW = 0.2388 kcal/s

in³ = lit. × 61.02 lb/PS.h = g/kW.h × 0.00162

hp = PS × 0.98635 cfm = m³/min × 35.336

lb = kg × 2.20462

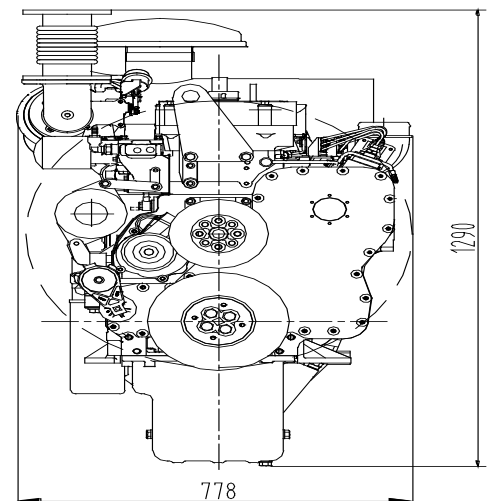
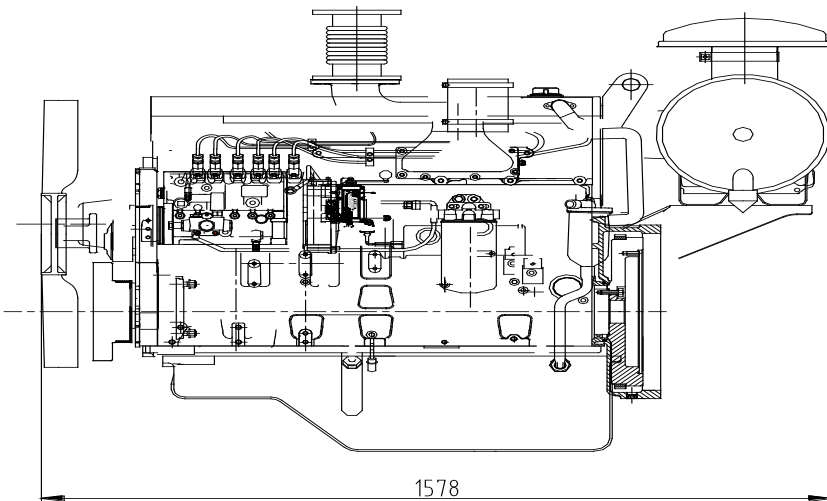

	Initial load acceptance when engine reaches rated speed (15 seconds maximum after engine starts to crank)				2nd load application Immediately after engine has recovered to rated speed (5 seconds after initial load application)			
	Engine speed	Prime power %	Load kWm (kWe) Nett	Transient Frequency deviation %	Frequency recovery time seconds	Prime power %	Load kWm (kWe) Nett	Transient Frequency deviation %
1500 rev/min	40	123	≤7	3	25	77	≤7	3