



Model:SC10E380D2

◎ POWER RATING

Engine Speed rpm	Type of Operation	Engine Power	
		kW	Ps
1500	Prime Power	255	347
	Standby Power	280	380

-. The engine performance is as per GB/T2820.

-. Ratings are based on GB/T1147.1.

---Prime power is available for an unlimited number of hours per year in a variable load application. The permissible average power output over 24 hours of operation shall not exceed 80% of the prime power rating.

---Standby power is available in the event of a utility power outage or under test conditions for up to 200 hours of operation per year. The permissible average power output over 24 hours of operation shall not exceed 80% of the standby power rating.

◎ SPECIFICATIONS

○ Engine Model	SC10E380D2
○ Engine Type	In-line,4 strokes, water-cooled 4 valves, Turbo charged air-to-air intercooled
○ Combustion type	Direct injection
○ Cylinder Type	Wet liner
○ Number of cylinders	6
○ Bore × stroke	128(5.04) × 135(5.31) mm(in.)
○ Displacement	11.8(720) lit.(in3)
○ Compression ratio	17 : 1
○ Firing order	1-5-3-6-2-4
○ Injection timing	14°BTDC
○ Dry weight	Approx.1070 kg (2,359 lb)
○ Dimension (L×W×H)	1787×918×1294 mm (70.4×36.2×51 in.)
○ Rotation	Counter clockwise viewed from

◎ FUEL CONSUMPTION

○ Power	lit/hr
25%	15.8
50%	32.1
75%	49.4
100%	60.8
110%	67.5

◎ FUEL SYSTEM	
○ Injection pump	Longkou in-line “P” type
○ Governor	Electric type
○ Feed pump	Mechanical type
○ Injection nozzle	Multi hole type
○ Opening pressure	250 kg/cm ² (3556 psi)



	Flywheel		○ Fuel filter	Full flow, cartridge type
○ Fly wheel housing	SAE NO.1		○ Used fuel	Diesel fuel oil
○ Fly wheel	SAE NO.14			
◎ MECHANISM		◎ LUBRICATION SYSTEM		
○ Type	Over head valve		○ Lub. Method	Fully forced pressure feed type
○ Number of valve	Intake 2, exhaust 2 per cylinder		○ Oil pump	Gear type driven by crankshaft
○ Valve lashes at cold	Intake 0.40mm (0.0158 in.)		○ Oil filter	Full flow, cartridge type
	Exhaust 0.65mm (0.0256 in.)		○ Oil pan capacity	High level 41 liters (10.82 gal.) Low level 33 liters (8.71 gal.)
◎ VALVE TIMING			○ Angularity limit	Front down 25 deg. Front up 35 deg.
	Opening	Close		Side to side 35 deg.
○ Intake valve	15 deg. BTDC	30 deg. ABDC		
○ Exhaust valve	45 deg. BBDC	13 deg. ATDC	○ Lub. Oil	Refer to Operation Manual
◎ COOLING SYSTEM		◎ ENGINEERING DATA		
○ Cooling method	Fresh water forced circulation		○ Water flow	515 liters/min @1,500 rpm
○ Water capacity (engine only)	23.2 liters (6.12 gal.)		○ Heat rejection to coolant	32.1 kcal/sec @1,500 rpm
			○ Heat rejection to CAC	11.2 kcal/sec @1,500 rpm
○ Pressure system	Max. 0.5 kg/cm ² (7.11 psi)		○ Air flow	17.3 m ³ /min @1,500 rpm
○ Water pump	Centrifugal type driven by belt		○ Exhaust gas flow	43.8 m ³ /min @1,500 rpm
○ Water pump Capacity	515 liters (136 gal.)/min		○ Exhaust gas temp.	600 °C @1,500 rpm
	at 1,500 rpm (engine)		○ Max. permissible	
○ Thermostat	Wax-pellet type		restrictions	
	Opening temp. 85°C		Intake system	3 kPa initial
	Full open temp. 95°C			6 kPa final



○ Cooling fan

Blower type, plastic
840 mm diameter, 8 blades

Exhaust system 6 kPa max.

○ Max. permissible altitude 2,000 m

◎ ELECTRICAL SYSTEM

○ Charging generator

28V×70A

○ Voltage regulator

Built-in type IC regulator

○ Starting motor

24V×5.5kW

○ Battery Voltage

24V

○ Battery Capacity

180 AH

◆ CONVERSION TABLE

in. = mm × 0.0394

lb/ft = N.m × 0.737

PS = kW × 1.3596

U.S. gal = lit. × 0.264

psi = kg/cm² × 14.2233

kW = 0.2388 kcal/s

in³ = lit. × 61.02

lb/PS.h = g/kW.h × 0.00162

hp = PS × 0.98635

cfm = m³/min × 35.336

lb = kg × 2.20462

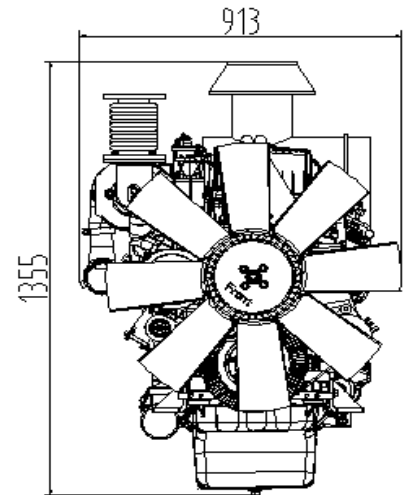
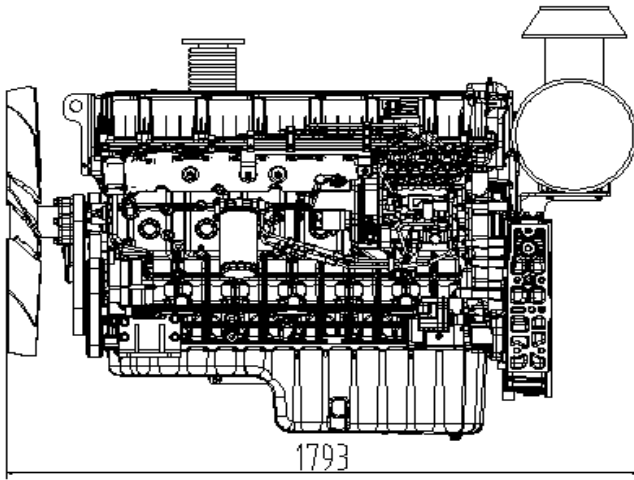

	Initial load acceptance when engine reaches rated speed (15 seconds maximum after engine starts to crank)				2nd load application Immediately after engine has recovered to rated speed (5 seconds after initial load application)			
	Engine speed	Prime power %	Load kWm (kWe) Nett	Transient Frequency deviation %	Frequency recovery time seconds	Prime power %	Load kWm (kWe) Nett	Transient Frequency deviation %
1500 rev/min	40	123	≤7	3	25	77	≤7	3